

DTC	P1662	Exhaust Bypass Valve Control Circuit Malfunction
------------	--------------	---

CIRCUIT DESCRIPTION

This valve controls the opening or closing of the exhaust bypass passage to ensure a smooth transition from 1 turbo operation to 2 turbo operation.

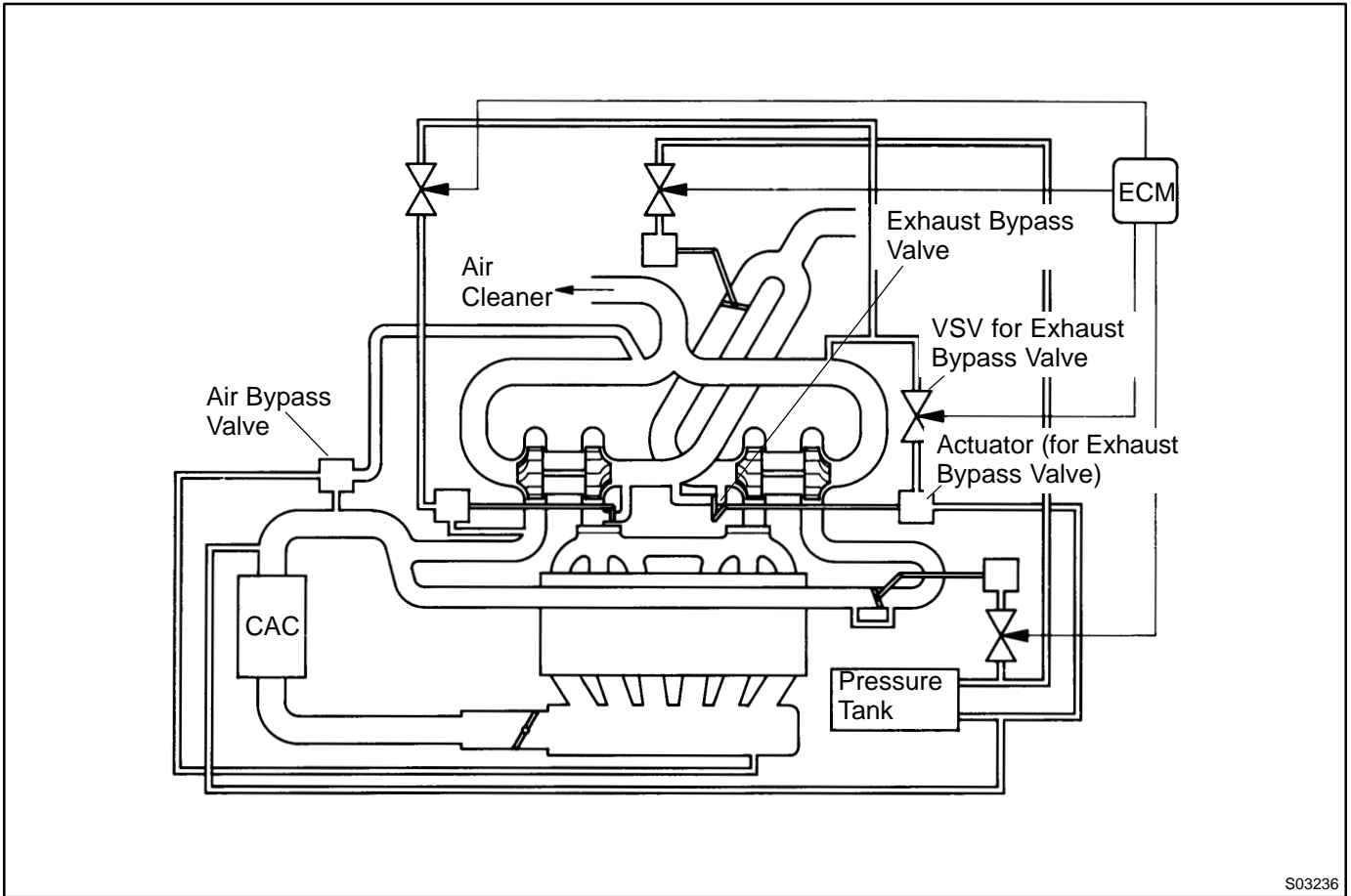

S03236

DTC No.	DTC Detecting Condition	Trouble Area
P1662	During idling, voltage level at the output terminal (VSV3) of ECM is low (2 trip detection logic)	<ul style="list-style-type: none"> • Open or short in VSV circuit for exhaust bypass valve • VSV for exhaust bypass valve • ECM

WIRING DIAGRAM

Refer to page [DI-266](#) for the WIRING DIAGRAM.

INSPECTION PROCEDURE

TOYOTA hand-held tester

- | | |
|----------|---|
| 1 | Connect the TOYOTA hand-held tester and check operation of VSV for exhaust bypass valve. |
|----------|---|

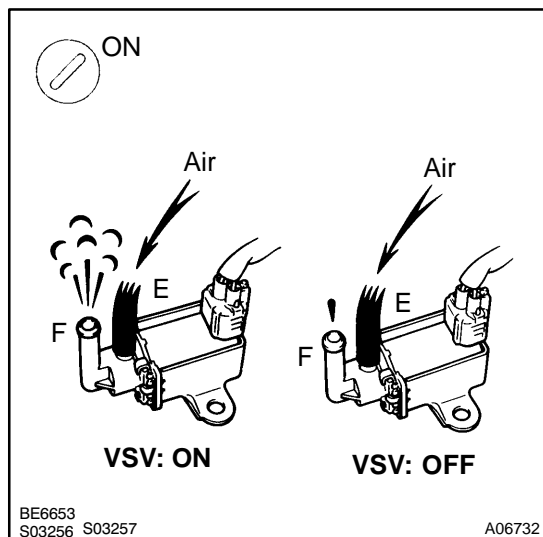
**PREPARATION:**

- Connect the TOYOTA hand-held tester to the DLC3.
- Turn ignition switch ON and TOYOTA hand-held tester main switch ON.
- Select the ACTIVE TEST mode on the TOYOTA hand-held tester.

CHECK:

Check operation of VSV when VSV is operated by the TOYOTA hand-held tester.

OK:

VSV is ON:

Air from pipe E flows out through pipe F.

VSV is OFF:

Air does not flow from pipe E to pipe F.

OK

Check for intermittent problems
(See page [DI-147](#)).

NG

- | | |
|----------|---|
| 2 | Check VSV for exhaust bypass valve (See page SF-67). |
|----------|---|

NG

Replace VSV for exhaust bypass valve.

OK

3 Check for open and short in harness and connector between EFI main relay (Marking: EFI MAIN) and ECM (See page [IN-28](#)).

NG Repair or replace harness or connector.

OK

Check and replace ECM (See page [IN-28](#)).

OBDII scan tool (excluding TOYOTA hand-held tester)

1 Check VSV for exhaust bypass valve (See page [SF-67](#)).

NG Replace VSV for exhaust bypass valve.

OK

2 Check voltage between terminal VSV3 of ECM connector and body ground.

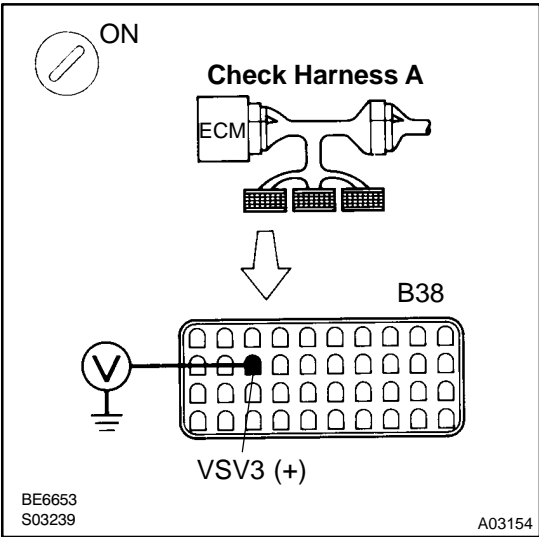

PREPARATION:
 (a) Connect Check Harness A (See page [DI-164](#)).
 (b) Turn ignition switch ON.
CHECK:
 Measure voltage between terminal VSV3 of ECM connector and body ground.
OK:
Voltage: 9 – 14 V

NG Check and repair harness or connector.

OK

Check and replace ECM (See page [IN-28](#)).