

CIRCUIT INSPECTION

DTC	P0100	Mass Air Flow Circuit Malfunction
------------	--------------	--

CIRCUIT DESCRIPTION

The mass air flow meter uses a platinum hot wire. The hot wire air flow meter consists of a platinum hot wire, thermistor and a control circuit installed in a plastic housing. The hot wire air flow meter works on the principle that the hot wire and thermistor located in the intake air bypass of the housing detect any changes in the intake air temperature.

The hot wire is maintained at the set temperature by controlling the current flow through the hot wire. This current flow is then measured as the output voltage of the air flow meter.

The circuit is constructed so that the platinum hot wire and thermistor provide a bridge circuit, with the power transistor controlled so that the potential of "A" and "B" remains equal to maintain the set temperature.

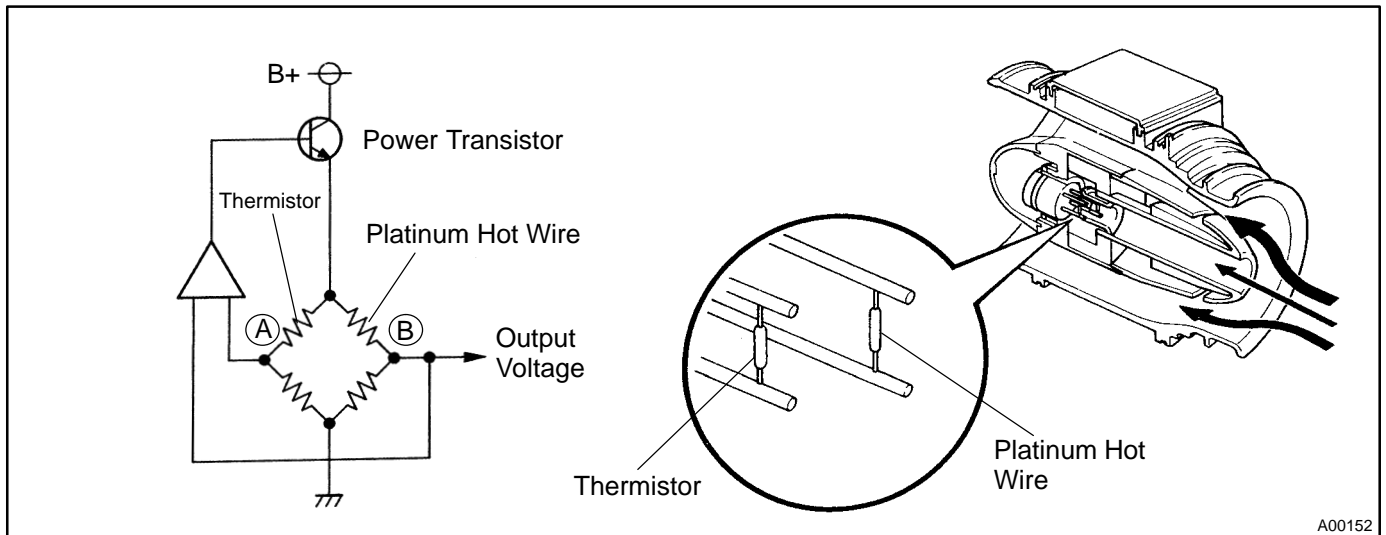

A00152

DTC No.	DTC Detecting Condition	Trouble Area
P0100	Open or short in mass air flow meter circuit with engine speed 4,000 rpm or less	<ul style="list-style-type: none"> • Open or short in mass air flow meter circuit • Mass air flow meter • ECM
	Open or short in mass air flow meter circuit with engine speed 4,000 rpm or more (2 trip detection logic)	

If the ECM detects DTC "P0100" it operates the fail safe function, keeping the ignition timing and injection volume constant and making it possible to drive the vehicle.

HINT:

After confirming DTC P0100 use the OBD II scan tool or TOYOTA hand-held tester to confirm the mass air flow ration from "CURRENT DATA".

Mass Air Flow Value (gm / sec.)	Malfunction
0.0	<ul style="list-style-type: none"> • Mass Air flow meter power source open • VG circuit open or short
359.0 or more	<ul style="list-style-type: none"> • VG - circuit open

WIRING DIAGRAM

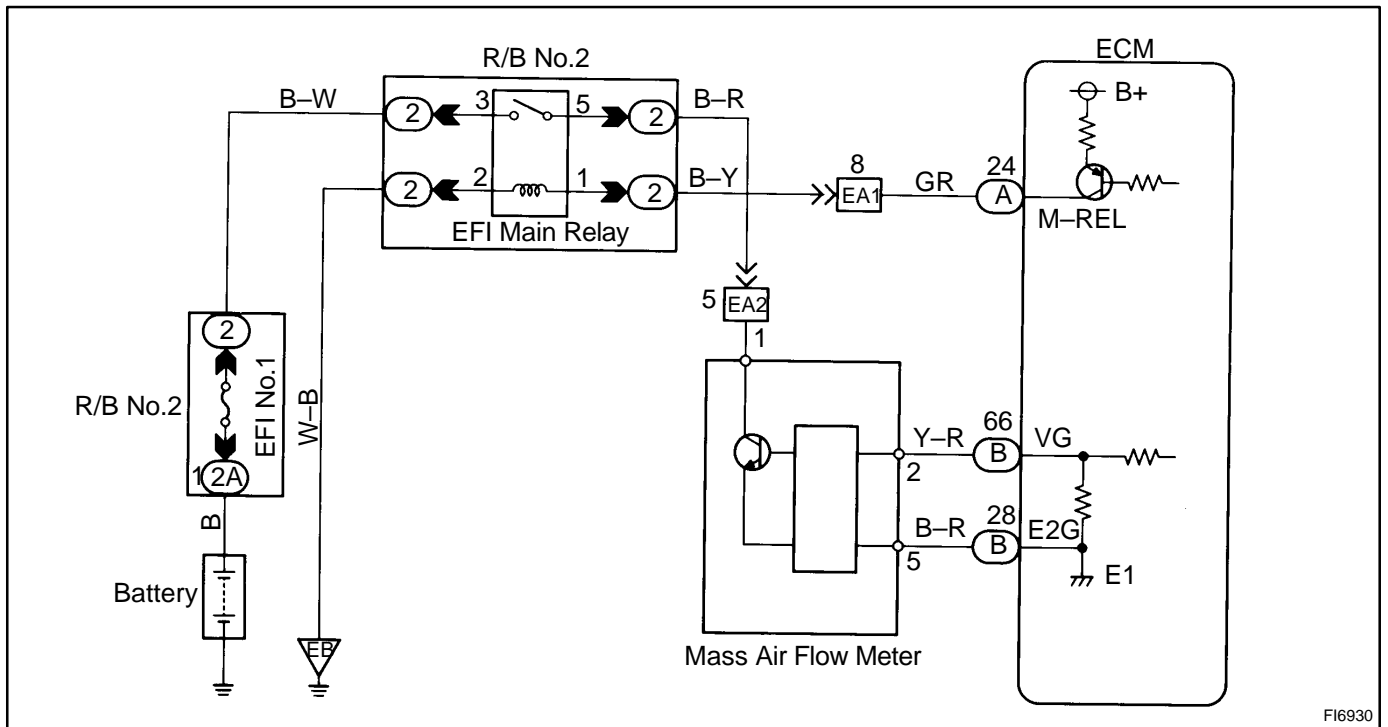

FI6930

INSPECTION PROCEDURE

- | | |
|----------|---|
| 1 | Connect the OBD II scan tool or TOYOTA hand-held tester, and read value of mass air flow rate. |
|----------|---|

RESULT:

- (a) Connect the OBD II scan tool or TOYOTA hand-held tester to the DLC3.
- (b) Turn ignition switch ON and push the OBD II scan tool or TOYOTA hand-held tester main switch ON.
- (c) Start the engine.

CHECK:

Read mass air flow rate on the OBD II scan tool or TOYOTA hand-held tester.

RESULT:

	Type I	Type II
Mass air flow rate	0.0 gm / sec.	359.0 gm / sec. or more

Type I	Go to step 2.
Type II	Go to step 5.

2 Check voltage of mass air flow meter power source.

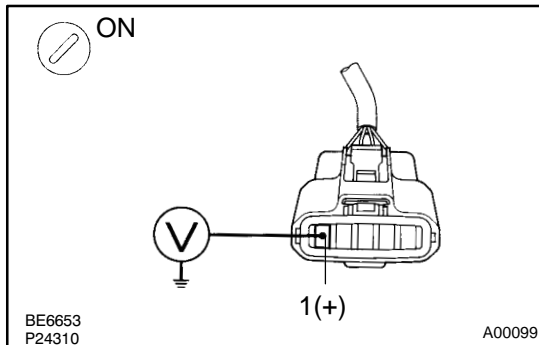

PREPARATION:

- Disconnect the mass air flow meter connector.
- Turn ignition switch ON.

CHECK:

Measure voltage between terminal 1 of mass air flow meter connector and body ground.

OK:

Voltage: 9 – 14 V

NG

Check for open in harness and connector between EFI main relay (Marking: EFI MAIN) and mass air flow meter (See page [IN-28](#)).

OK

3 Check voltage between terminal VG of ECM and body ground.

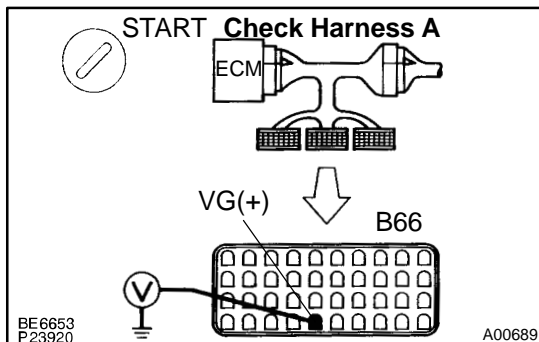

PREPARATION:

- Connect Check Harness A (See page [DI-164](#)).
- Start the engine.

CHECK:

Measure voltage between terminal VG of ECM and body ground while engine is idling, transmission is in park or neutral position and A/C switch is OFF.

OK:

Voltage: 1.1 – 1.5 V

OK

Check and replace ECM (See page [IN-28](#)).

NG

- 4 Check for open and short in harness and connector between mass air flow meter and ECM (See page [IN-28](#)).

NG

Repair or replace harness or connector.

OK

Replace mass air flow meter.

- 5 Check continuity between terminal E2G of ECM and body ground.

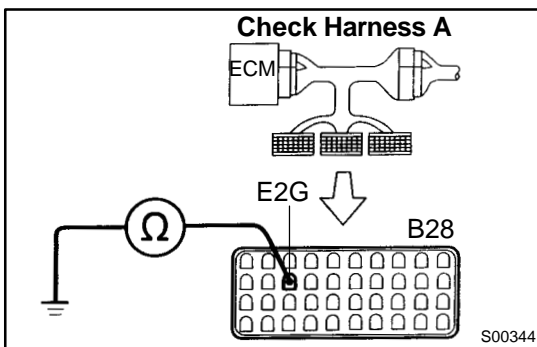
**PREPARATION:**Connect Check Harness A (See page [DI-164](#)).**CHECK:**

Check continuity between terminal E2G of ECM and body ground.

OK:

Continuity (1 Ω or less)

NG

Check and replace ECM (See page [IN-28](#)).

OK

- 6 Check for open in harness and connector between mass air flow meter and ECM (See page [IN-28](#)).

NG

Repair or replace harness or connector.

OK

Replace mass air flow meter.